

# DEAD CENTER

## FEATURES

- Accuracy guaranteed to 0.002m TIR (0.0001")
- Excellent for built-in-tail stock machines.
- Heat-treated point to HRC 60 ± 2.
- Draw-off nut type. (Help to easy release from tail-stock.)
- Carbide point available.
- Carbide point to HRA 90 ± 5.

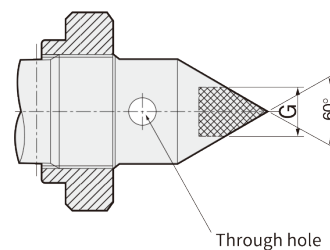
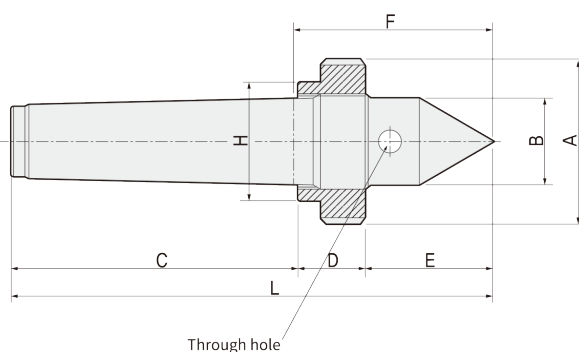

### Available Carbide Tipped Points DCC-TYPE

- MT3: 132003
- MT4: 132004
- MT5: 132005
- MT6: 132006

## Dimension

Unit: mm. kg

MODEL	MT	A	B	C	D	E	F	H	G	L	Weight	Max, Run out
131003 (132003)	3	50	24	82	16	42	59	40	10	140	0.8	0.002
131004 (132004)	4	60	32	104	24	47	72.5	43	14	175	1.3	0.002
131005 (132005)	5	80	45	131	30	60	93	58	18	221	3.0	0.002
131006 (132006)	6	100	60	187	30	72	107	78	30	289	6.9	0.002

\* (MODEL NO) : Carbide Tip Type