

BP80

FEATURES

- Accuracy guaranteed to 0.003mm TIR (0.0001")
- Excellent for heavy duty lathe applications.
- For pipe work, tube work and parts with extra-large center holes.
- Heat-treated point to HRc 60 ± 2.
- Adjust the shaking of the head part with screw.
- The design prevents ingress of coolant and chips.

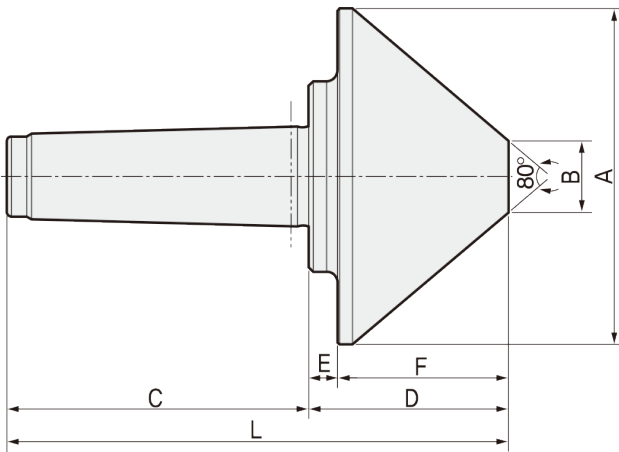

Dimension

Unit: mm. kg

MODEL	MT	A	B	C	D	E	F	L	Workpiece Weight	Max, R.P.M	Weight	Max, Run Out
083003	3	95	20	85	60	10	50	145	400	4,000	2.4	0.003
083004	4	125	29	108	77	13	64	185	800	3,000	3.9	0.003
083005	5	150	32	136	90	13	77	226	1,600	2,000	6.9	0.003
083006	6	200	38	189	120	15	105	309	2,500	1,500	17	0.005

BP80 type Technical data

- 3BP80
- 4BP80
- 5BP80
- 6BP80

